

robot coupe[®]



R23 • R30 • R45 • R60

VERTICAL CUTTER-MIXERS

NEW MODELS



INSTITUTIONS - DELICATESSENS - CATERERS - RESTAURANTS - CONFECTIONERS

 **R23 • R30 • R45 • R60**



R23 • R30 • R45 • R60



1

Control panel

- 0-15 minute **timer**. When the appliance is used, it automatically repeats the processing time selected on the previous occasion, unless the user sets a different one.
- **Stainless-steel control buttons flush with the casing**, making them easier to clean and longer lasting.
- **Safety indicator lights** to ensure risk-free use.
- **Pulse control** for greater cutting precision.



5

Bowl

- **tilting bowl** making it easier to empty.
- **Removable bowl**, exclusive to Robot-Coupe, for hassle-free cleaning.



2

Lid

- **Transparent polycarbonate lid** to enable user to monitor processing.
- **Watertight lid** requiring a single movement to lock it into position.
- Lid specially designed to direct liquid back into processing bowl when opened.
- **Opening in centre of lid** for adding liquid or dry ingredients during processing.
- **Lid and seal designed to be dismantled** simply and quickly for thorough cleaning.



6

Tilting lever

- Ergonomic lever enabling the user to tilt the bowl at various angles, even horizontally.



3

Lid wiper (optional extra)

- To wipe the inside of the lid, thereby ensuring perfect visibility during processing.



7

Wheels (optional extra)

- **3 retractable wheels** making it easier to move the appliance in order to clean the surface underneath.



4

Bowl-base blade assembly

- Exclusive to Robot-Coupe, ensuring total homogeneity of processed foodstuffs, even when small amounts are involved.



8

Frame

- 100% stainless-steel with system of 3 sturdy built-in legs :
 - ensuring total stability of the appliance and risk-free use,
 - taking up very little space,
 - making cleaning easier.

VERTICAL CUTTER-MIXERS



The Products Plus :

High Performance :

- Vertical Cutter Mixers have been designed for processing both large and small quantities.
- The cutter allows the processing of meat, vegetables and smooth-textured mousses, as well as for grinding and kneading foodstuffs in a minimum of time.
- Less than 5 minutes are needed to realise even the longest preparation such as smooth-textured mousses.

Cut quality :

- New patented blade for an optimum cut quality.
- To guarantee perfect cutting quality and perfect homogeneity of products even in small quantities.

Ease of use :

- All stainless steel machine for space saving, built with a removable bowl and tilting seal for easier cleaning and to empty the bowl easily.
- Control panel designed for a simple and reliable use and equipped with a timer for a better preparation control.



Number of covers :
100 to 3000 +



Quantities processed by operation :
From 4 to 35 kg



Target :

Institutions, Delicatessens, Caterers, Restaurants, Confectionners



In brief :

New generation of stainless steel Vertical Cutter Mixers with high capacity removable bowl and tilting seal (from 23 to 60 litres according to the model) satisfying all the professionals requirements.

Delivered with a smooth 3-blade assembly.



The blade shaft can be fitted with 2 blades for processing small amounts, the 3 blade assembly being used for maximum quantities. To obtain the best results, it is important to get the spacing between the blades right and to take into account the maximum processing capacities (see table).

Three different types of edge :

As a standard



Smooth edge for emulsions, mousses and the fine mincing of meat and vegetables.

Optional extra



Serrated edge for cake-making (grinding almonds, hazelnuts, making icing sugar), for frozen goods and all hard foodstuffs.

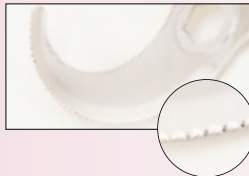

Fine serrated edge for all blending tasks, as well as for homogeneous and smooth-textured preparations. Recommended for chopping parsley.

Models	R23	R30	R45	R60
Bowl capacity (in litres)	23	28	45	60
Speeds	1500/3000	1500/3000	1500/3000	1500/3000
Timer	●	●	●	●
No of serving	100-400 +	100-500 +	200-1000 +	300-3000 +
Maximum quantities processed				
Coarse mincing	10 kg	12 kg	18 kg	25 kg
Emulsion	12 kg	14 kg	24 kg	30 kg
Kneading (in kg of flour)	7 kg	8 kg	12 kg	18 kg
Grinding	5 kg	6 kg	9 kg	12 kg

MINCING	EMULSIFYING	KNEADING	GRINDING
Minced meat, steak tartare, hamburger, stuffing for tomatoes, country pâté, sausage, chopped vegetables, garlic, parsley, onions, shallots, purées, soups, compotes, etc.	Liver paste, fish mousse, galantine, white pudding, brandade, quenelle, flavoured butters, mayonnaise, sauces, etc.	Shortbread, sweet pastry, flaky pastry, savarin mix, choux pastry, cake mixes, special breads, biscuit, brioche dough, pizza dough.	Grinding fruit, shellfish, breadcrumbs, crushed ice, ground almonds..., almond paste, praline, hazelnut purée, chocolate and hazelnut paste.

VERTICAL CUTTER- MIXERS



Surprise Brioche



3-pepper purée



Hommos (Chickpea purée)



Hot, spicy sausages



Mayonnaise, green mayonnaise sauce, cocktail sauce

robot coupe®

R23 • R30 • R45 • R60

Dimensions (in mm)

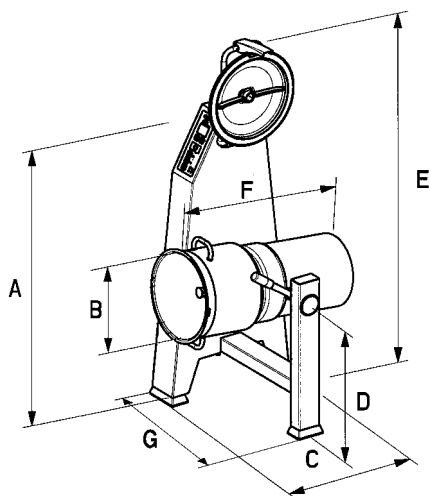

	R23	R30	R45	R60
A	1250	1250	1400	1400
B	320	360	400	450
C	600	600	600	600
D	590	590	640	640
E	1620	1620	1800	1820
F	800	800	870	870
G	700	720	760	810

CE Mark

Electrical data

Speeds 1500 - 3000 Rpm
 400 V/50 Hz - Three-phase
 R23 : 4500 W - 18 Amp.
 R30 : 5000 W - 18 Amp.
 R45 : 6700 W - 24 Amp.
 R60 : 10 000 W - 35 Amp.

Other voltages Bar

Weight

R23 : Net 110 kg Gross 131 kg
 R30 : Net 110 kg Gross 131 kg
 R45 : Net 138 kg Gross 165 kg
 R60 : Net 150 kg Gross 177 kg

As inventors and market leaders, Robot-Coupe offers the most complete range of Table-Top Cutter Mixers, a choice of **models** with capacities ranging from **2.5 litres to 60 litres**.



STANDARDS : MACHINES IN COMPLIANCE WITH :

- The following European directives and related national legislation: 98/37/EEC, 73/23/EEC, 89/336/EEC, 89/109/EEC, 90/128/EEC.
 - The following European harmonized standards and standards setting out health and safety rules: EN 292 - 1 and - 2, EN 60204 - 1 (1992), EN 12852.
- INDEXES OF PROTECTION: • IP 65 for the switches. • IP 34 for the machines.



MADE IN FRANCE BY ROBOT-COUPÉ S.N.C.

Head Office, French, Export and Marketing Department:

Tel.: + 33 1 43 98 88 33 - Fax: + 33 1 43 74 36 26
 18, rue Clément Viénot - BP 157 94305 Vincennes Cedex - France
<http://www.robot-coupe.fr> - email : international@robot-coupe.com

Robot-Coupe Australia: Tél.: 02-9417 6233 - Fax : 02-9417 6787
 P.O. Box 146 - Northbridge NSW 1560 - <http://www.robotcoupe.com.au>

Robot-Coupe U.K. LTD: Tel.: 020 8232 1800 - Fax : 020 8568 4966
 2, Fleming Way, Isleworth, Middlesex TW7 6EU
<http://www.robot-coupe.co.uk>

Robot-Coupe U.S.A.: Ph.: 1-800-824-1646 - Fax : 601-898-9134
 P.O. Box 16625 - Jackson, Mississippi 39236-6625 -
<http://www.robotcoupeusa.com>

DISTRIBUTOR

ROTOR

Rotor Lips Ltd.
 Engineering works
 CH-3661 Uetendorf
 Switzerland
 Phone +41 (0)33 346 70 70
info@RotorLips.ch
www.RotorLips.ch

We reserve the right to alter at any time without notice the technical specifications of this appliance. None of the information contained in this document is of a contractual nature. Modifications may be made at any time. © All rights reserved for all countries by : ROBOT-COUPÉ S.N.C.